



WestminsterLab
Rei Operational Manual

Index

1. Note to customers, music lover
2. Cautions
3. Package contents
4. Unpacking and installation
5. Names of parts
6. Setting Up
7. Connecting the amplifier
8. Operation
9. Maintenance
10. Error signal
11. Troubleshooting
12. Opinions to obtain best performance
13. Warranty terms
14. Specification
15. Legal information

| Note to customers, music lovers

Thank you for purchasing the Rei amplifier.

Wholeheartedly and sincerely built in Hong Kong, the Rei amplifier crystallizes craftsmanship, skills, simplicity, science and listening experiences.

It is dedicated to every music lover who would like to experience music as it is. Or further, experience music itself.

Sincerely,
WestminsterLab Team

2 Cautions

- I. NO USER SERVICEABLE PARTS INSIDE. Do not open the amplifier's chassis or remove any of its screws. Contact WestminsterLab or your dealer if you have service needs.
- II. WARNING! Do not expose this amplifier to moisture or excessive humidity, and do not use it outdoor. Fire hazard may be resulted.
- III. Presence of uninsulated "dangerous voltage" within the product's enclosure may be of sufficient magnitude to constitute a risk of electrical shock to persons.

3 Unpacking & Package contents

Your Rei amplifiers should be coming in two sdeperate boxes. The units should have matching serial number. In case of discrepencies, please contact your dealer.

Unpacking the amplifier from the box

Please lift the amplifier with meticulous care for the amplifier is about 16kg. It is recommended to move it to a location near the place where it will be installed when the amplifier is still in its case. Remove all jewellery including watches, rings and belts to avoid damages to the exterior of the amplifier during the removal and installation.

If any of the following items are missing, please contact your dealer:

- I. 2 Rei monoblock amplifier
- II. 1 user manual

4 Installation

Unpacking the amplifier from the box

Please lift the amplifier with meticulous care for the amplifier is about 16kg pounds. It is recommended to move it to a location near the place where it will be installed when the amplifier is still in its case. Remove all jewellery including watches, rings and belts to avoid damages to the exterior of the amplifier during the removal and installation.

Installation and precautions

Before any installation or connection, it is a MUST to make sure the AC mains voltage matches the specification of the amplifier. (E.g. 110V for Japan, 110V for US, 230V for UK) The AC mains voltage specification & serial number of the specific amplifier is written on the plaque located at the back of the unit.

Improper input of the AC mains voltage will permanently damage the amplifier and it is not within the warranty conditions.

WARNING! NEVER unplug any cables during operation. It may cause failure or damage to the amplifier and speakers. Be sure that the amplifier is off with NO LED illumination in the front before unplugging any cables. It is even safer to unplug the AC power cord before unplugging other cables.

It is suggested that there is adequate ventilation for the amplifier and place it on a stable and safe surface.

5 Name of parts

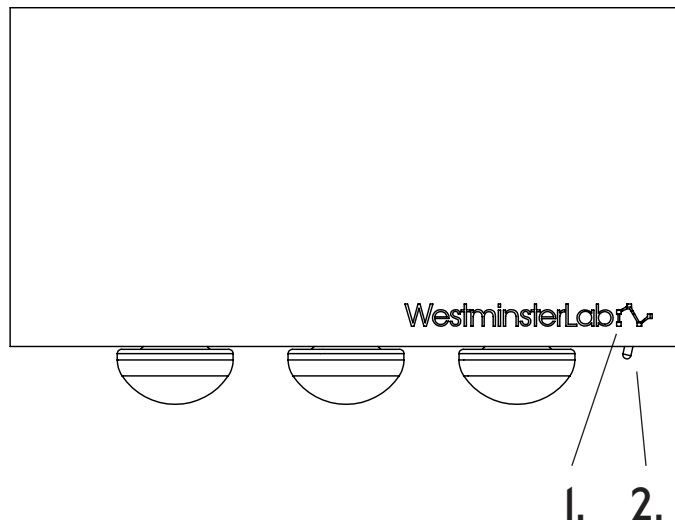

- 1. LED indication
- 2. Main Switch

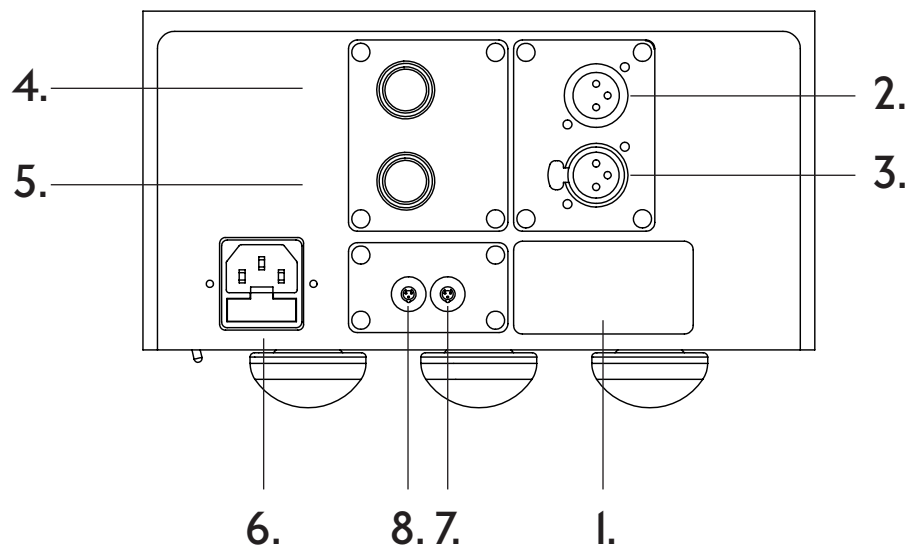

- 1. Unit serial & Voltage specification
- 2. XLR bypass socket
- 3. XLR input socket
- 4. Positive binding post
- 5. Negative binding post
- 6. AC inlet
- 7. Trigger input (Option)
- 8. Trigger output (Option)

6 Setting up

Remove the Rei amplifier from the canvas bag and place the unit on the desired operating location. Make sure the unit is switched off (toggle left when facing the amplifier 's front) before you connect any cables.

WARNING! Resting the amplifier on its own weight on the ON/OFF switch may result in non-reversible damage.

7 Connections

Single / Bi / Tri Amplification Operation

Balanced Audio connection

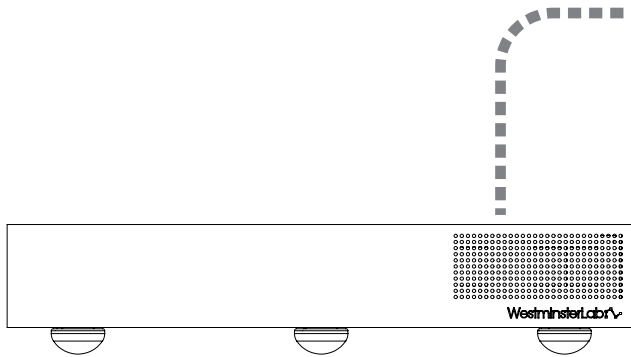

Pre-amplifier / Audio Source
(With Volume Control)

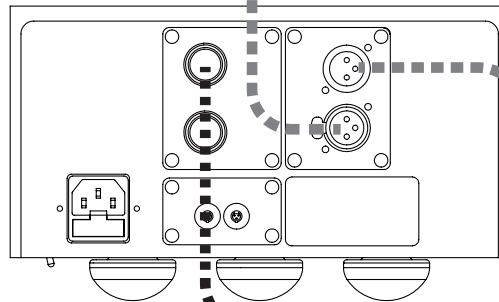

Rei
(1st Pair)

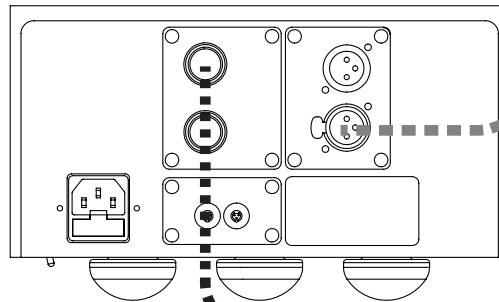

Daisy chain to another set of
Rei for Bi/Tri Amplification

Rei
(2nd Pair)

Connect set/sets of
speaker cable according to
the polarity on both ends

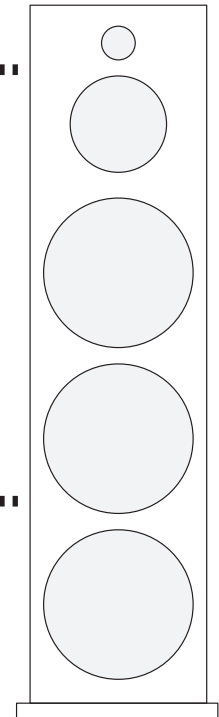

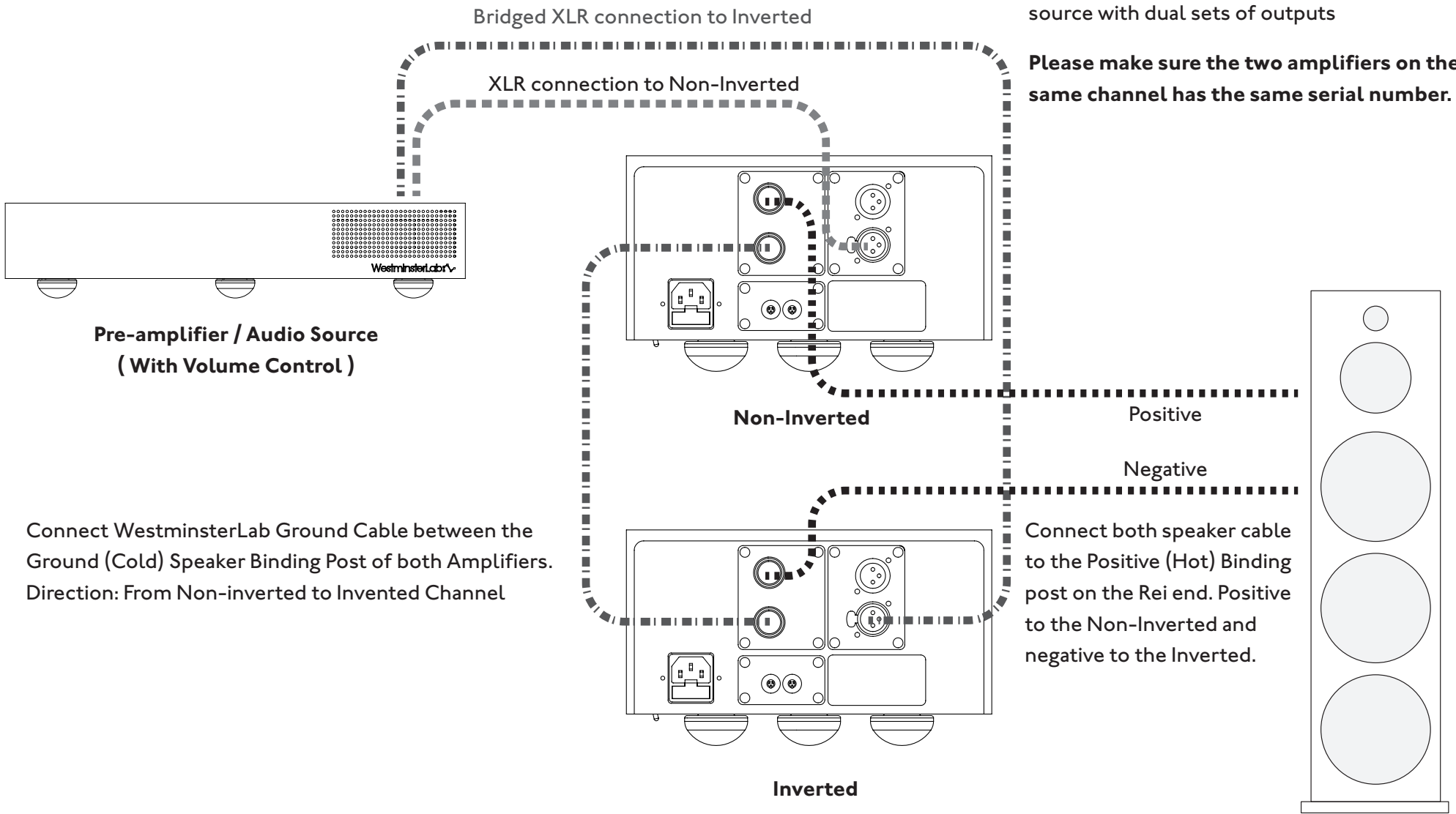

Bridged Amplification Operation (Config 1)

This setup is suitable for pre-amplifier/audio source with dual sets of outputs

Please make sure the two amplifiers on the same channel has the same serial number.

Connect WestminsterLab Ground Cable between the Ground (Cold) Speaker Binding Post of both Amplifiers.
Direction: From Non-inverted to Inverted Channel

Connect both speaker cable to the Positive (Hot) Binding post on the Rei end. Positive to the Non-Inverted and negative to the Inverted.

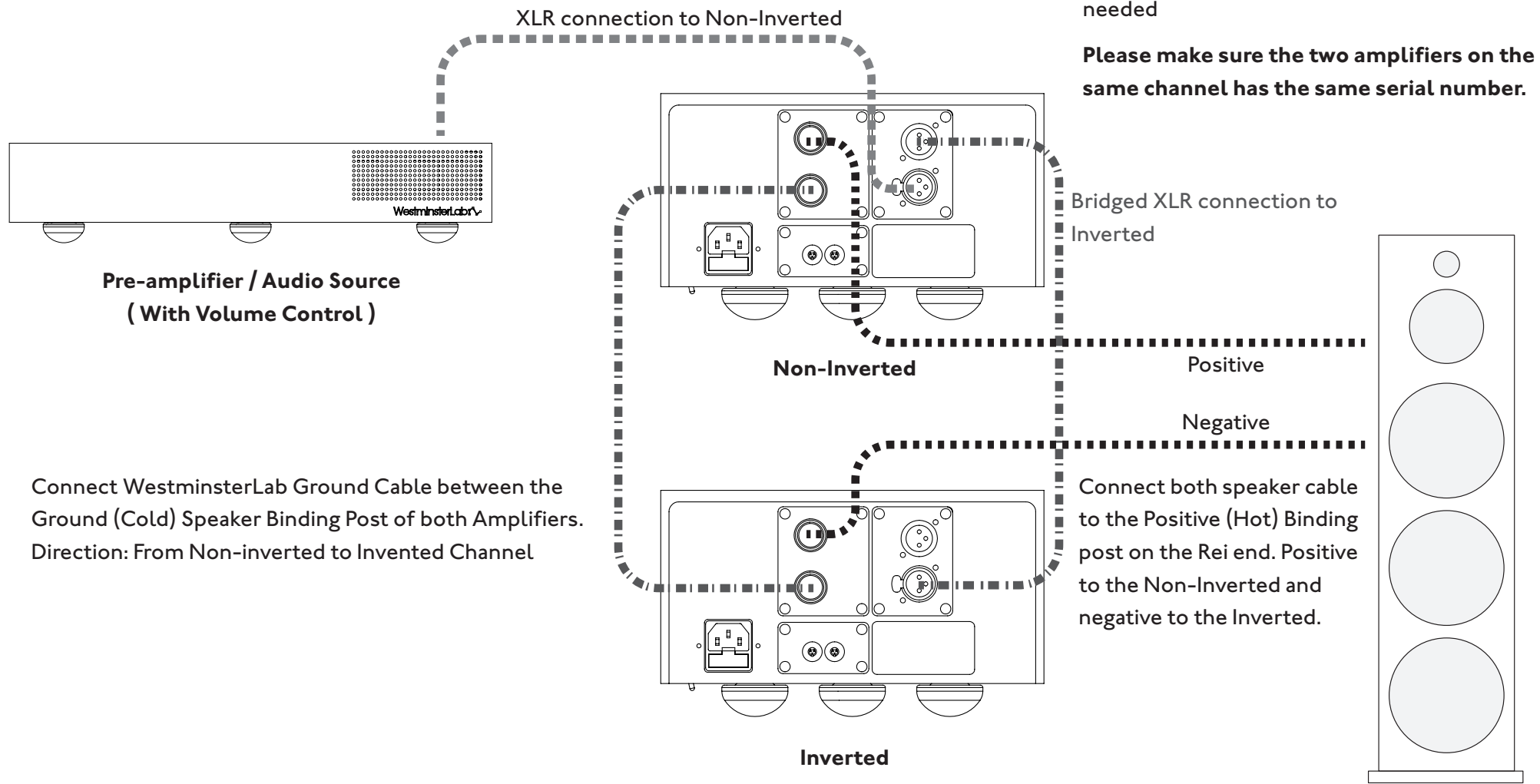

Bridged Amplification Operation (Config 2)

This setup is suitable for pre-amplifier/audio source with only one set of output or system where dual-mono bridged configuration is needed

Please make sure the two amplifiers on the same channel has the same serial number.

Connect WestminsterLab Ground Cable between the Ground (Cold) Speaker Binding Post of both Amplifiers.
Direction: From Non-inverted to Inverted Channel

8 Operation

Initial power-up of the amplifier

PLEASE be sure that all cables are connected correctly before power-up. Missing or loose XLR input cable or shorting the speaker cables may cause failure and non-reversible damage to the amplifier and speaker. All 3 pins of the XLR cable must have a valid connection to the source or preamp.

The power switch is located on the front right underside edge of the amplifier. Ticking the toggle to the right will power up the amplifier. The front LED should illuminate as RED and within 20 seconds change to WHITE, which means the amplifier is now ready for operation.

After the power is switched on, the amplifier requires approximately 30 minutes to reach optimal operating condition. Although the amplifier will sound excellent upon initial listening, the sound quality will improve as it warms up.

During operation

The Rei amplifier requires no adjustments during normal operation. If there is no sound or the sound quality is in some way impaired, consult the “Troubleshooting” section in this manual.

WARNING! NEVER unplug any cables during operation. It may cause failure or damage to the amplifier and speakers. Be sure that the amplifier is off with no LED illumination in the front before unplugging any cables. It is even more safe to unplug the AC power cord before unplugging other cables.

9 Maintenance

Maintenance & cleaning

The Rei amplifier requires no user maintenance other than to keep it clean to maintain its heat dissipation performance. It is recommended to use a very soft cloth to gently wipe the amplifier's surface without any liquids or solutions. To maintain the best exterior, please keep the surface from oil and grease. Be aware not to scratch the surface of the amplifier.

Services

Please contact WestminsterLab directly for services / overhaul on the Rei.

10 Protection

Within the amplifier, there are DC output protection and overheat protection. When there is a certain amount of DC in the output, the DC output protection will be triggered and the front LED will illuminate as red. This may be caused by a high DC amount in the input, unplugging input cable during operation, or failure of the amplifier. When the DC amount drops to safety level for a period of time, the protection will turn off by itself and the front LED will turn to white.

When the amplifier is overheated, the overheat protection will be triggered and the front LED will illuminate as red. This may be caused by too low loading impedance, high environment temperature, overloading the amplifier (close to or exceed the rated output), or failure of the amplifier. When the temperature drops to safety level, the protection will turn off by itself and the front LED will turn back to white.

With safety in mind, the Rei has a built-in overload protection. Therefore, please be careful not to short the speaker cables or the binding posts or input wrong AC mains voltage. The mentioned operation will permanently damage the amplifier which is not covered by warranty.

|| Troubleshooting

Amplifier does not power up

If the front LED is not illuminated, follow the procedures below. If one step succeeds in activating the power, stop and ignore the other steps.

Check if the AC mains voltage matches the specification of the amplifier. Do not connect the AC power cord if they do not match. This will damage the amplifier permanently. Always use a power cord with ground wire connected.

1. Check if the power switch is ticked to right side. It is located at the front underside edge of the amplifier.
2. Check to make sure the AC cord is plugged into the wall outlet.
3. Check the back of the amplifier to make sure the IEC connector is pushed all the way into the socket on the back of the amplifier.
4. Unplug the power cord and check if the fuse is blown. Replace with the same type and rating only. (In US, use only a 10 amp, slow-blow fuse.)
5. Check your household electrical box to make sure the circuit breaker has not been tripped. If it has, flip the breaker back on.
6. If the breaker trips again, make sure the power cord has no damage and can work properly. You may try the power cord by using it with other home appliances. Change the power cord if it is not working.
7. Check the speaker cable connection on the amplifier and the speaker to make sure that the terminals are not shorted, and check the entire length of the cable to ensure there has been no damage.
8. If all of these steps fail to return power to the amplifier, consult your dealer for service.

Front LED is illuminated as red and no sound

When the soft start and DC protection are initiating, the front LED will illuminate as red and there will be no sound. Within one minute the LED should illuminate as white and there should be sound. If the LED still illuminates as red:

1. Switch off the amplifier and test again until it cools down. If this does not work, the amplifier may be overheated. Make sure not to overload the amplifier. Placing it at where ventilation is better is preferred.
2. If it still doesn't work, switch off the amplifier and unplug the input XLR cable. Short the 3 pins of the XLR input socket (you may need help from technicians or dealers). Switch on again and check if the LED turns white within a minute. If it does, it means there may be DC in the input which triggers the DC output protection. Make sure to have a pure signal AC input without DC from the source.
3. If all of these steps fail to restore sound, consult your dealer for service.

Front LED is illuminated as white but you hear no sound

Switch off the amplifier first. Follow these steps in order. If one step succeeds in restoring the sound, stop there and ignore the other steps.

1. Check the cables between the amplifiers and the speakers to make sure they are properly connected and that the cables are not damaged or shorted.
2. Check your preamp and source device to make sure they are both turned on.

3. Check the source device to make sure there is a signal output, i.e. if it's a record player, make sure it's spinning and the tonearm is lowered, or if it is a CD player, make sure it is in play mode and not in pause, or file playing for computer/network streamer/file player.
4. Make sure your preamp is not muted and the desired source is selected.
5. Check the line-level connections between the source device and the preamp, and between the preamp and the amplifiers. Reconnect any cables that may be disconnected or loosen.
6. Try using another pair of interconnect cables (even cheap ones will work temporarily) instead of which are being used between the source device and the preamp and between the preamp and the amplifier. If this restores sound, replace the defective cables.
7. Try using another pair of speaker cables (even cheap ones will work temporarily). Remove the clear plastic ring on the WBT binding post if needed. If this restores sound, replace the defective cables.
8. If you are using daisy chain, unplug the XLR bypass cables and test only the Rei amplifier which is connected to the source or preamp. If this gives sounds, the bypass XLR cables may be defective. Replace and try once again.
9. If all of these steps fail to restore sound, consult your dealer for service.

12 Opinions to obtain best performance

- I. Place on a rigid, stable, heavy mass surface.
- II. Use one Rei amplifier for each speaker unit/order. Each amplifier handles less loading and results in a better performance in dynamics, handling and power.
- III. Warm up for more than 45 to 60 minutes.
- IV. Put the amplifier as close as possible to the speaker and keep the speaker cable as short as possible. It is preferable to use a long balanced interconnect cables to the amplifier and keep the speaker cable length minimized. Speaker cables add impedance to the loading in which power will be wasted in the cable, decreasing the overall performance.
- V. It is recommended to use a dedicated AC power cord rated at a minimum of 13 amps for 230V mains, or 20 amps for 110V mains. We highly recommend WestminsterLab power cables to obtain the best experience and performance. Power conditioner and also regenerator are also not recommended for Rei.

13 Limited Warranty

WestminsterLab warrants the Rei monoblock amplifier against manufacturing defects and defects in materials for three years from the date of purchase from an authorized WestminsterLab dealer, subject to the conditions listed below:

1. The warranty covers only new Rei amplifier (product or products) by WestminsterLab purchased from an authorized WestminsterLab dealer.
2. The warranty is non-transferable and is valid only for the original purchaser.
3. The warranty is valid only if the product has been used according to the instructions in the owner's manual. Damage due to accidents, owner abuse or negligence is not covered under this warranty.
4. All service must be performed by an authorized WestminsterLab dealer. Damage resulting from service by other parties is not covered under this warranty.
5. All products returned for service must be packaged in the original container and must include an original / photocopy of the original purchase receipt. If the original container has been lost or discarded, contact WestminsterLab or WestminsterLab dealers for a replacement.
6. If the product must be shipped back to WestminsterLab for warranty service, the customer shall bear the shipping costs. WestminsterLab will pay for return shipping.
7. Before shipping the product to WestminsterLab for service, the customer must first obtain a Return Authorization (RA) number from WestminsterLab. The RA number must be marked clearly on the side of the package.

8. WestminsterLab has the right to choose whether repairing the product by using new or refurbished parts.
9. This warranty covers only defects in products made by Westminster-Lab. It does not cover incidental or consequential damages, force majeure, or damages to other products resulting from defects in WestminsterLab products.
10. Your authorized importer or dealer bears the direct responsibility for warranty coverage of your amplifier. Please contact your importer or dealer with requests for service under warranty. WestminsterLab will work with your importer or dealer to assure that the terms of the warranty are fulfilled.

14 Specification

Rei

Power

100 watts @ 8Ω

200 watts @ 4Ω

400 watts @ 2Ω

Frequency Response

5Hz to 40 kHz, ±0.1 dB

2 Hz to 52 kHz, -1 dB

Distortion

(100 watts @ 8Ω)

<0.1% @ 1 kHz

Signal-to-Noise Ratio

103 dB, unweighed

Damping Factor

>870 (5hz to 20khz)

Input

1 balanced XLR input

Output

1 balanced XLR output

2 X WBT Binding Post

Input Impedance

200 kΩ

Output Impedance

0.018Ω

Dimensions

W232 x H112 x D320 mm

Weight

16KG

15 Legal information

The information in this owner's manual is subject to change without notice.
Current Version of this manual was produced by the WestminsterLab Ltd..

The information in this manual is the sole property of WestminsterLab Ltd..
Any reproduction in whole or part without the expressed written permission
of WestminsterLab Ltd. is prohibited. No material herein may be transmitted
in any way including either electronic or mechanical methods for any purpose
without expressed written permission of WestminsterLab Ltd..